



SUR-RON

User Manual



Light
Bee

The logo for the 'Light Bee' model, featuring the words 'Light' and 'Bee' in a stylized, outlined font. A silhouette of a bee is positioned to the right of the word 'Bee'.

High performance electric off-road bike

www.surron.com



TO

We will launch the reform trend of China's high-end electric bicycle together. Thank you for your trust and care for every knight who chooses sur-ron technology products.



D

ear Sir/Madam

Welcome to buy our products, and sincerely hope that you will provide us with valuable advice and suggestions when using our products. Your satisfaction is the best wish of our company.

The company is a manufacturers to design electric vehicle professionally. The electric vehicle we designed, developed and produced has the advantages of novel appearance, comfortable riding, easy operation, strong power, long cruise range and safe and reliable. It is the ideal new generation of green transportation. In order to make the electric car a better service for you, please read the instruction manual carefully before using, fully understand the performance and use and maintenance methods of the vehicle. so that you can use the car

correctly, give play to the best performance, reduce malfunction and prolong service life.

Do not lend to people who can not drive electric cars. When you drive, you must wear safety helmets and obey traffic rules strictly. Please drive in slow lane.

Slow down and keep car distance in rain, snow and slippery areas to ensure safety

As the company's products are constantly improving and the products are different from the real products, please take the material object as the criterion, and the final interpretation right belongs to the company.





C ontent

I、precautions for safe driving	001
II、A schematic diagram of vehicle parts	002
III、Function and operation of each part	006
IV、correct use and driving operation	010
V、Use of battery and charger	014
VI、Check before driving	018
VII、Regular inspection and simple maintenance	021
VIII、Main technical parameters and specifications	026
IX、Fault phenomenon and elimination	029
X、Electrical schematic diagram of the vehicle	031





I、Precautions for safe driving

Please obey the traffic rules and control the speed within the safe speed. (the maximum speed of this car is 45km/h)

Before you drive, please familiarize yourself with the contents of the instructions and find an open and safe field to master the driving essentials of the car and be familiar with its structure, which is the basis for safe driving.

warning

Do not lend it to or let it be used by people who are not familiar with it or who cannot drive it. It's dangerous to drive by one hand or drive after drinking.

We must pay more attention to safety when driving in rain and snow

The wet and slippery road in rain and snow will bring danger! Avoid driving at high speed. swerve carefully and brake ahead of time to prevent accidents.

Wear a helmet of good quality and fasten the buckle belt.

Correct dress:

Wear clothes with bright colors, not tight, without open cuffs and your body can move freely. Please do not wear slippers or high heels when driving vehicles.

The load should not be too heavy

When loading and unloading, the vehicle handling sense is different. Too much loading will seriously affect the operation and risk. The rated occupant of the vehicle is 1 people. Please do not overload so as to avoid driving safety hazards and parts.

Caution

In order to facilitate maintenance, repair and service, the company has a unique frame number and motor number for each vehicle, so as to help the marketing unit to provide you with better service.

The frame number is engraved on the side of the vertical pipe in the direction of the frame.

The motor number is engraved on the motor body.

II、A schematic diagram of vehicle parts

Please refer to the figure to identify the vehicle body parts and be familiar with the vehicle





- 1-1 front brake handle
- 1-2 acceleration handle
- 1-3 pedal
- 1-4 cushion
- 1-5 side stand—vehicle can not start when side stand is on
- 1-6 combination switch
- 1-7 instrument
- 1-8 handlebar
- 1-9 coulomb meter
- 1-10 USB charging socket(2.1A)
- 1-11 electric door lock
- 1-12 Rear brake handle
- 1-13 front turn lamp
- 1-14 rearview mirror
- 1-15 rear turn lamp
- 1-16 license plate bracket

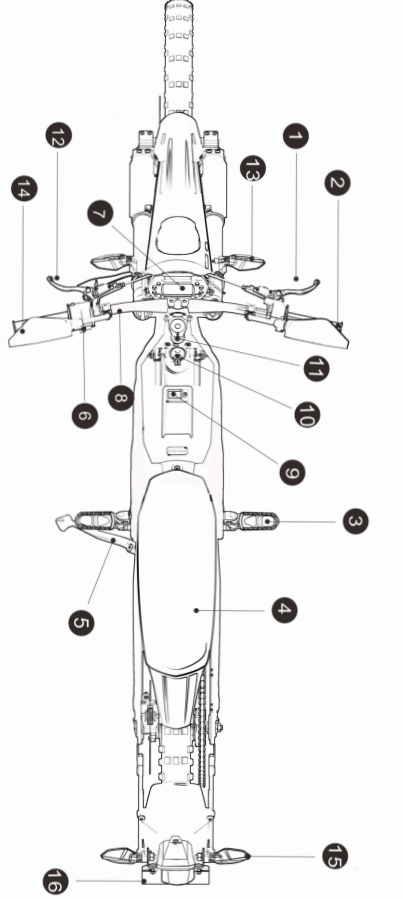

- 2-1 headlamp
- 2-2 front shock absorber
- 2-3 machine controller
- 2-4 Front disc brake pump
- 2-5 front wheel
- 2-6 Battery charging port
- 2-7 Battery chamber cover
- 2-8 frame
- 2-9 rear fender
- 2-10 taillight/reflector
- 2-11 bottom fork
- 2-12 rear disc brake pump
- 2-13 rear-wheel
- 2-14 rear reflector
- 2-15 Side reflector

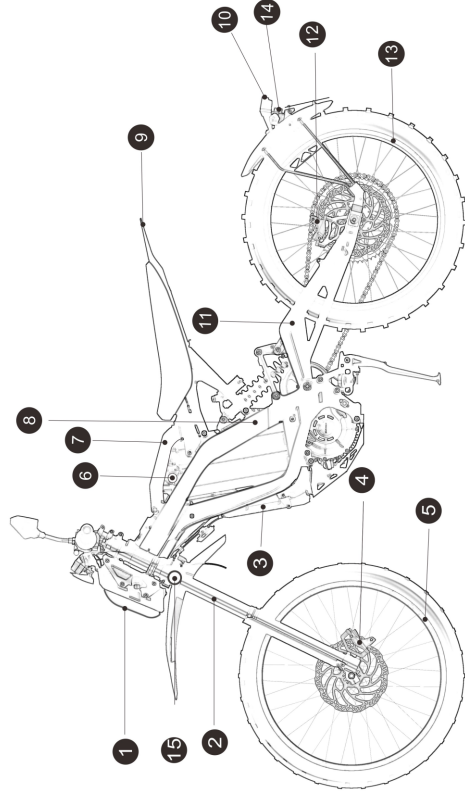



- 3-1 lithium battery pack
- 3-3 rear shock absorber
- 3-5 Motor protection board
- 3-2 battery chamber lock
- 3-4 drive motor
- 3-6 Warning horn

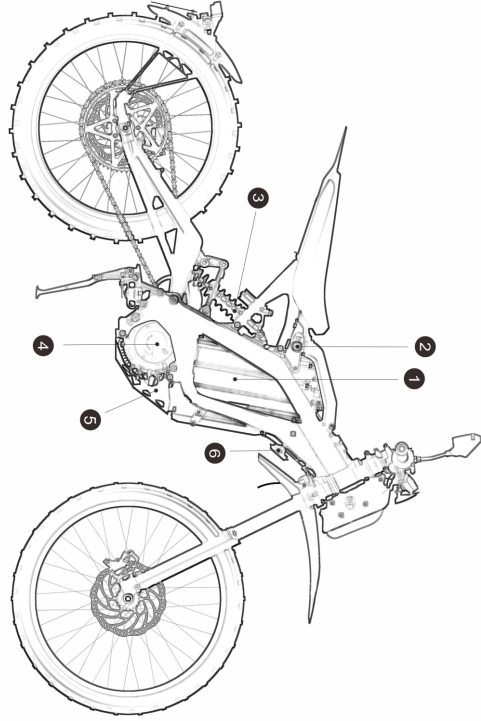

III、Function and operation of each part

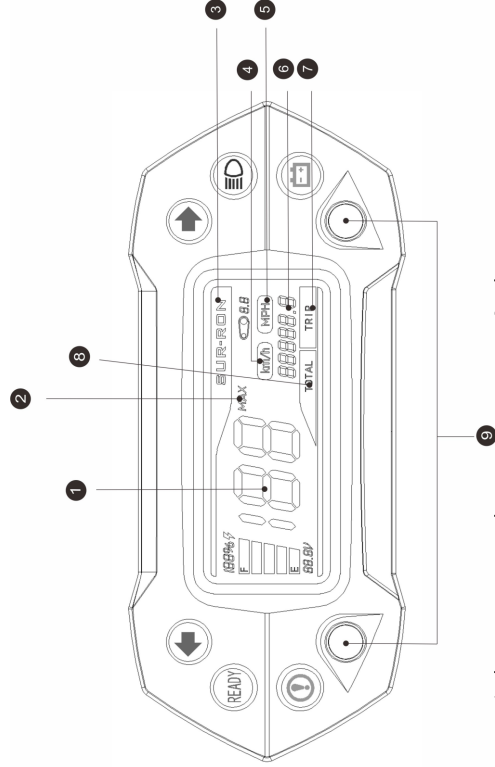

- 4-1 The current speed
- 4-2 Maximum speed
- 4-3 brand logo
- 4-4 km/hour
- 4-5 mile/hour
- 4-6 odometer
- 4-7 Single mileage
- 4-8 total mileage
- 4-9 selection button of instrument function



5-1 indicator control
 5-2 Power mode button
 5-3 horn button
 5-4 oil immersion lens

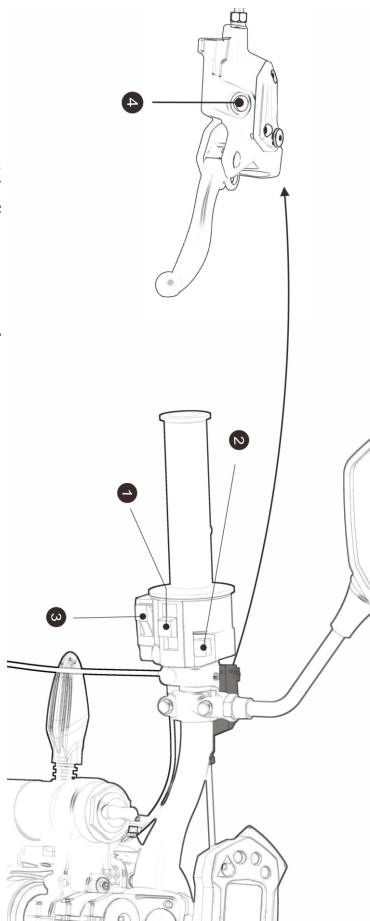

Each area function:

1-6 combination switch used to set up the power mode, turn the signal switch, start the alarm horn.

1-9 battery meter. You can click to view the remaining battery power.

1-10 USB power interface. Supply power to USB devices with maximum current 2.1 A.

1-11 electric door lock. Start motor and vehicle function in 0 N operation position,

2-6 battery charging port. Connect the charger to charge the battery.

3-2 battery chamber lock. Turn the key counterclockwise to open the battery lock.

4-1 current vehicle speed.

4-2 maximum speed. When the mark is displayed, it represents the maximum speed in the previous driving period.

4-4 and 4-5 are kilometers and mile of speed and mileage, which can be switched by means of instrument buttons.

A 4-6 odometer. Used to show the total mileage of a



vehicle or a single trip.

4-7 and 4-8 are used to switch the odometer to show the total mileage or single mileage, which can be switched by the key of the meter.

Switch adjustment and setting: 1-5 combination switches have power mode switches 5-1 and 5-2. When the switch is in 5-1 position, the vehicle is set to "economical" mode and the vehicle is the operation mode of limiting power and maximum speed. This mode is suitable for beginners and continuous driving. When the switch is in 5-2 position, it is in "motion" mode and the vehicle is full power output, which is suitable for play and off-road conditions.

009

function description of instrument buttons:

A. When the instrument is electrified and the vehicle is not running, press the left key short time more than one second and the small mileage and the total mileage display and the small mileage and the maximum speed are synchronously displayed, and the speed meter is showing the current speed when the vehicle runs.

B. When the meter is energized and the vehicle is not running, press the right key long time more than two seconds under small mileage model and the mileage and the highest speed are cleared simultaneously.

C. Hold down the left key before the meter is energized, and keep it more than two seconds after it is energized. Switch the display of metric system and British units;

D. Hold down the right key before the meter is energized, and keep it more than two seconds after it is energized and then enter the transmission ratio setting mode. At this time when the symbol of transmission ratio setting is flashing and flashes 1 time one second, press the left or right key short time one second to adjust transmission ratio. If you press left key, the ratio will decline 0.1. And if you press right key, the ratio will increase 0.1. After setting up, press right key more than two seconds to complete.

V、 Use of battery and charger

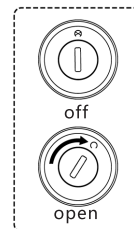
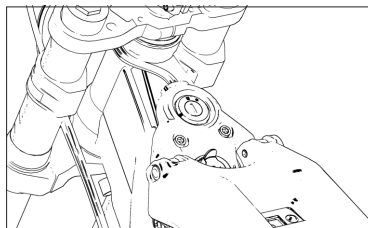

010





Starting method

Before starting: standing on the left side of the car to check the vehicle.

1. first check whether the air switch in the front of the battery chamber opens to the ON position. Then close the battery bin, insert the lock key into the lock, turn right to the ON position (operation), and check whether the switches, instruments and speakers are normal, and hold the brake handle back and forth to check the braking function.

2. motor starting: the side bracket is collected. After the driver sits down on the electric car, slowly and steadily turns the handle to start. The vehicle has a power-off protection of side bracket. When the side bracket supports the vehicle, the motor can not start.

Speed adjustment

The speed control handle is usually closed and turn it inward to speed up and turn it outside to slow down. Relaxing it will automatic reset and motor will stop. Gently turn the speed control handle to avoid speeding up too quickly.

The speed control handle can be used to speed up and slow down. Please turn it smoothly and soft and do not

operate violently, avoiding danger or damage to vehicle parts.

Use of brake

1. Quickly reset the speed regulating handle, hold the left and right brake handle, and apply appropriate force.

2. The grip force on the brake handle should be controlled according to the actual situation, and the gradual increase is the most reasonable.

3. Try to make a judgment in advance, so as to avoid sharp braking, sharp steering and other operations that may cause side slip and fall, especially when the road is slippery on rainy days, which is extremely dangerous.

Caution when driving

1. On the premise of ensuring safety, drive as smoothly as possible to avoid rapid acceleration and deceleration, so as to save electricity, protect vehicle body parts, and improve the endurance and service life of the vehicle.

2. In rainy and snowy weather, the road surface is easy to slip when it is wet and slippery. After cleaning the vehicle or wading through water, the braking effect may be reduced. At this time, you should drive the vehicle slowly, pay attention to safety, and gently brake several times until the brake





returns to normal.

3. Please avoid riding in heavy rain or on waterlogged road. If surface water surpass center of wheels, motor and brake may be affected. This electric car can be used in the rain and snow, but not for wading deeply long time. Once the water depth over the controller and other electrical components, appliances may be damaged.

4. Caution

The side bracket can only be used to support the vehicle. It is forbidden to open the side bracket and sit on the vehicle. This will damage the side bracket.

Don't park your car on a tilt or in a soft spot to prevent it from toppling over!

The electric vehicle contains many electrical components. Do not get wet for a long time or use a high pressure water gun to flush parts with electrical components.

Parking method

1. Pay attention to the rear situation and slow down to the parking place.

2. Use brake to stop the car, reset the speed control handle. After the car stops, close the electric door lock and take off the key.

3. After parking, you should stand on the left side of the car and stop the car firmly by opening the side bracket. When you leave, please lock the electric door lock, the front direction lock and the battery lock and take away the key.

warning

It is strictly prohibited to turn the speed control handle before you seat. In case of accidents, the electric lock key will be closed immediately after getting off the bus.

V. use of battery and charger

1. Our car has lithium-ion batteries with high-performance high-magnification, safe (48 v) voltage 60 v and can be used at the environment temperature from 20 °C to 50 °C. The using effect at the ambient temperature 10-30 °C is the best. The low or high ambient temperature will affect the battery performance and service life. Do not use it at a temperature beyond the allowable range. The battery should not be charged at 0 degrees centigrade.

warning

It is forbidden to charge the battery below 0 degrees,, otherwise it will damage the battery. The battery can be recharged after the battery temperature rises.

2. When the temperature is too low, the battery





performance will be affected. It is normal to reduce the mileage in a small amount. The battery performance will automatically recover after the temperature rises.

3. The car battery have perfect protection function. It can avoid the battery damage caused by overcharge and over-discharge but long-term use depth discharge will affect battery performance. When power is low, the battery should be charged as soon as possible.

4. Charge frequently. The lithium battery used in this car has no memory effect, and can be charged at any time. Charging at any time helps keep the battery healthy.

5. When you do not use it for a long time, please charge the battery to 60% and close the air switch of the car body. The battery needs to be charged once every 3 months to avoid losing its activity and affecting the performance.

Caution

Using only front brake or rear brake is prone to sideslip and combined braking is safer.

When the motor temperature and the controller temperature is too high, or the battery power is too low, in order to protect the safety of the whole vehicle, the vehicle will automatically reduce the power to operate. This is not a

fault.

Battery charge and charger use

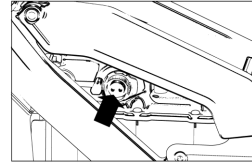

Vehicle charging mode

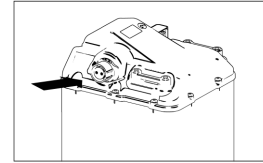

External charging mode

1. The car uses a lithium battery charger. Please do not use other chargers, so as not to damage batteries or cause any danger.

2. Check whether the input voltage of the charger is in line with the grid voltage AC110V-220V.

3. The charger can be directly inserted into the battery charging socket on the left side of the car body.

4. The right is the lithium battery used by the car and the left silver socket is the charging socket, and the charger's output plug (battery end) is inserted first, and then the charger is inserted into the plug.

5. The indicator light of the charger is flashing, indicating that it is full. When the indicator light is always on, it





indicates that it is full. The time to charge fully depends on the battery's remaining power and charger specifications users selected. The time to charge fully is about 3 hours.

6. when the charger is full, it will shut down automatically, but you should avoid connecting the charger to the power grid for a long time. The longest time can not exceed 6 hours.

7. it is strictly forbidden to disassemble the battery by itself, so as to avoid damage and danger.

8. when the battery is protected through excessive discharge, it needs to activate and charge the battery by pressing the red reset button on the charger.

Precautions for charging

When charging, please place it in a safe place where children are not allowed to touch.

Avoid being used when the battery is just full. After being full of power, stand for 10 minutes and then use it.

When the charger is used, it is forbidden to cover any object. Please use it in a dry and well ventilated environment.

when you are charging, if you find that peculiar smell or the temperature is too high or charger is still not full after

charging for a long time, please stop charging immediately and send it to the maintenance service.

Use and maintenance of motor and controller.

1. Regularly check whether the motor screws are loose.
2. Regularly check whether the connection between motor and controller is loose and the insulation status.
3. Regularly check whether the fuse is loose.
4. Do not drive in the over-deep water, so as not to affect the electrical work.

VI、 Check before driving

Tire inspection

1. Whether the tire pressure is normal. Note:
Abnormal tire pressure, damage, abnormal wear and tear, etc. will cause safety hazards.

A lack of air pressure can lead to abnormal wear and tear, poor steering, low speed and short endurance.

High tire pressure can lead to abnormal wear, flat tire and it is uncomfortable and even cause safe hidden trouble. You can judge whether the pressure is appropriate according to the partial depression when tires connect the land. In





general, normal front wheel pressure is 225 kpa and the rear wheel is 225 kpa, (under-inflated will affect the speed and endurance mileage)

2. Whether the tires have cracks and abnormal wear.
3. There are no nails, stones, glass and other foreign bodies embedded in the tires.
4. The depth of tire tread and the bump on the tire should be replaced when 2/3 of the wear is worn out.
5. Whether the spokes of the wheel ring are loose.

Caution

Abnormal tire pressure, damage, abnormal wear and tear, etc. will cause driving safety hazards. A lack of air pressure can lead to abnormal wear and tear, poor steering, low speed and short endurance mileage

Excessive tire pressure will lead to abnormal wear, poor comfort, and even puncture, causing safety hazards.

warning

The car has a 300km running time, and the new car should be maintained for the first time after 300km. After the grinding period, a maintenance is carried out at 1000 KM

Check the meter, horn and brake

1. Open the electric door lock to check whether all parts of the meter function display normally.
2. Operate the switch and check whether the horn works normally.
3. Hold the left and right brake handles respectively to check whether the front and rear brakes work normally.

Check handlebars and seat cushions.

Whether the handlebar seat cushion is well adjusted and fixed reliably.

If you find any problem after inspection, please read the related content of this manual or contact the dealer to provide you with perfect after-sales service.

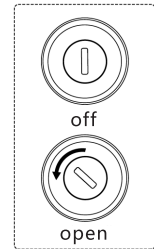
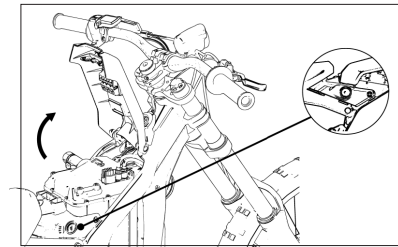

1. Close the electric lock, use the vehicle key to open the





battery lock on the right side of the car body, and then open the battery cover forward to see the battery.

2. Turn off the air switch in front of the battery to the left, remove the discharge and communication plug on the battery, then pull up to take out the battery and close the battery cover.

Install the battery

1. Use the key to open the battery cover.

2. Put the battery from the top, pay attention to the front and rear direction of the battery (the charging socket is facing the left side of the car body), and plug in the communication and discharge plug. Then turn on the air switch to the right, close the battery compartment cover and lock it, and remove the key.

Pay attention to

The air switch must be turned off before inserting or pulling out the battery.

Must connect the communication plug, otherwise the car body cannot correctly identify the battery specification.

VII、Regular inspection and simple maintenance

In order to extend the service life of the vehicle and make it safe and comfortable, please check and maintain the vehicle regularly. When the vehicle is stopped for a long time, regular inspection should also be carried out.

When the new car is running 300KM, it should be inspected and maintained.

Take full care of safety during inspection

1. Park your car in a wide, flat area.

2. When inspection is required, it should be carried out in a safe place and pay attention to the surrounding environment and conditions.

3. If any abnormality is found through inspection, please drive after removing the abnormality. If it is difficult for you to solve, you can entrust the maintenance station to check.

Caution

The front and rear brakes are disc brakes. When the brake friction plates wear badly, the friction plates should be replaced.

In daily use, please keep the disc brake system clean, avoid attaching sediment for a long time, especially avoid oil pollution.





Inspection of operation site.

1. Check whether the front shock absorber is bent, deformed and damaged.

the front shock absorber has no damage, looseness, oil leakage, etc. Shaking handlebars up and down to check whether there is abnormal sound caused by the front shock absorber. when the front shock absorber is abnormal, please go to the service shop for inspection and maintenance.

2. Check the rear shock absorber
3. Brake inspection

Check the gap of brake handle to see if it is within the specified range (1, 5-30mm).If the measurement fails to meet the requirements, it shall be adjusted.

4. Braking effect and inspection

Run on dry and flat road at low speed and use the front and rear brakes respectively to check their respective braking effect.

Inspection of tires, etc

1. Check the air pressure with the tire barometer when the tire is cooling.
2. Check for cracks, damages, foreign matters and

abnormal wear and tear.

3. Check whether the spokes of the wheel ring are loose.

4. Check the tension of the chain. The distance between chain top and bottom is 10-15mm.(note: manufacturer has been adjusted the tensioning of leather when they leave the factory. Please do not adjust them privately.)

If vehicle tire contacts with the ground for a long time, stone, glass, nails and other foreign bodies on the ground will cause damage on your tires. So you should pay attention to watch the road when driving and avoid driving where something may damage the tires. In addition, you should regularly check whether the tires have obvious crack damage, foreign bodies such as stones, glass piercing in it, reasonable abnormal wear and tear.

5. Check the depth of tire groove

Please check tire for wear and the depth of tire groove, and replace the tire when the wear reaches 2/3 of the bump. When there is abnormal sound and swing of the tire during driving, please go to the maintenance station to check and repair it. It is recommended that the locking torque of the middle axle is 30n.m, and the locking torque of the rear axle nut is 40n.m.





Caution

Hold the brake handle tightly. If it still can't achieve the desired braking effect, the disc should be checked for cleanliness, but if the problem still cannot be solved and it should be sent to the maintenance station for inspection.

Battery inspection

The car uses a sealed ternary lithium battery, which needs to be filled during inspection, and then uses a multimeter to measure the positive and negative voltage. The full voltage should be normal between 66.5 and 67.2. Otherwise, if not, please go to the maintenance station for inspection.

Caution

Please close the electric door lock and turn the air switch to the left before getting out or loading the battery.

If the battery cannot be pushed in, do not force it. Pull out the battery to check whether the battery is stuck due to foreign matter.

Replace fuse

If vehicle instrument, horn and lamps still cannot work after opening air switch and electric lock, it is possible that fuse is fused. Before changing fuse, please close air switch

first.

1. Open the battery cover and pull out the battery. Open it and you can see the fuse box and open the fuse box.

2. Remove the broken fuse, take out the spare fuse from the cover and install it. Close the fuse box, install the battery and close the battery cover.

Caution

The fuse should be fixed firmly. If it is loose, the fuse may heat up and cause other hazards.

To replace fuse, we must use the fuse with the corresponding specification. If it exceeds the specification, it will not lead to fuse protection.

If a fuse is broken after a short time, the reason should be checked excluding the fuse.

The fuse should be avoided by the strong flow of water.

VIII、 Main technical parameters & specifications

The vehicle size : 1860X780X1050mm

The wheelbase : 1230mm

The vehicle weight/including battery weight : 42kg/50kg





Rated load : 100kg
Minimum ground clearance : 270mm
High : 810mm
Front dip : 26 degrees
Maximum climb slope : 70%grade
The maximum speed : 40Km/h
Power system : brushless middle motor with high speed DC
Motor rated power : 3000W
Maximum output power of motor : 4000W
Maximum torque of drive wheel : 240N.m
The battery type specification : 60V32AHhigh - power ternary lithium battery 60V32AH
The battery life of a single charge : 70-100Km
Charging time : 3-6h (depending on the charger)
Charger input voltage : AC110/220V-50/60Hz
The battery overcurrent protection value : 100A
Dynamic mode : economy/sports mode
Body type : all-aluminum alloy frame
type of wheel body : aluminum alloy

Tire type : 70/100-19 tire for crossing country
Front suspension system : 200mm, Shoulders front fork, distance of travel is 200mm, adjustable
rear suspension system : central chamber with Multi-link hydraulic spring
distance of travel : 85mm , adjustable
Front brake type : 203mm hydraulic disc brake
Rear brake : 203mm hydraulic disc brake
The first class transmission system : HTD 8M皮帶560mm
The second class transmission system : 420 chains 104 joints
system of lamp : LED lamp
The instrument type : LCD
Mobile phone charging interface : USB-5V 2100mA standard interface
Product certification : European standard certification of whole vehicle and parts

Note:

due to continuous improvement of the product, the listed performance parameters shall be subject to change without prior notice.





IX、 Fault phenomenon and elimination

9-1 power on, the motor does not work

Failure cause

1. The battery connection is loose
2. Fall off of control joint in speed regulation
3. The motor connection wire is loose or falls off.
4. The brake handle does not return or the brake switch

fails

solution

1. Check whether the connection line is firmly connected
- 2 Whether the plug connection is stable or not
- 3.reconnect and fasten it
- 4.Check the brake handle and brake switch

9-2 failure of speed governing or low maximum speed

Failure cause

1. battery voltage is too low
2. speed control is broken

solution

1. Fill the battery with electricity

2. Send to after-sale maintenance and replace speed control.

9-3 short range after one charging

Failure cause

1. tire pressure is insufficient
2. insufficient charge or charger failure
3. brake adjustment is improper, driving resistance is too large
4. battery aging or damage
5. more uphill, adverse wind, frequent acceleration and deceleration, heavy load

solution

1. Charge the tire to the right pressure.
 2. sufficient electricity or check the charger plug contact.
 3. readjust the brake.
 4. replace battery
 5. it is normal to reduce endurance in this environment
- 9-4 charging fault

Failure cause

1. Charger plug off or loose



2. the plug of Battery connector loosen

solution

1. open battery cover and plug closely
 2. Open the battery cover and plug in
- 9-5Abnormal sound of vehicle body in driving

Failure cause

- 1., chain tightness is not reasonable

solution

1. adjust tightness of the chain.
- 9-6 other failures

Failure cause

1.when you encounter failures or undetermined failures that cannot be ruled out under the above guidance.

solution

1.In case of the above situation, please contact the supplier or repair station, do not unlock the above parts, otherwise you will lose the warranty commitment of the company.

X、Electrical schematic diagram of the vehicle

